

Thermostatic/Pressure balanced mixer 9000-series

FM Mattsson

English

1000237

Rev. 001 – 09.11

Operating instructions

The left knob controls the water flow rate. The right knob controls the water temperature. Turned clockwise the mixer will provide cold water. The more it is turned anti-clockwise the warmer water is supplied. After one complete turn, the override button must be pressed in order to obtain warmer water. The knob can be turned another 1/2 turn after releasing this safety device. **The delivered water will then be warmer than normally needed for bath or shower.** The mixer is also available with temperature knob without override button (for limited temperature regulation) and with a cover instead of a knob (for fixed temperature setting).

Changing over to the shower outlet (Tub mixers)

When the valve is opened, the water is supplied through the spout. If instead water from the shower is desired, the diverter button is pulled upwards. When the valve is shut off, the diverter automatically resets to spout flow. Tub mixer FMM 9203 is not equipped with a connection for shower.

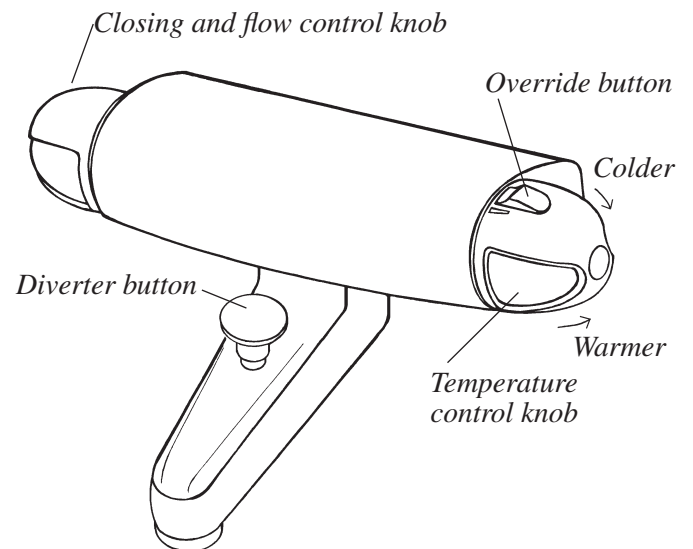

Function

The temperature is regulated in the mixer by a temperature control and pressure balanced interplay. The pressure balancing piston, operating inside the regulating shuttle, is first handling the cold and hot water. The piston continuously finds the position where cold and hot water gets equal pressures when entering the temperature regulating function.

The position of the regulating shuttle is controlled by the temperature knob, or by the spindle for fixed temperature setting. The sensor element is located between the shuttle and the knob and compensates for the temperature fluctuations of entering cold and hot water from the supply. The outgoing mixed water is delivered with an even, stable temperature.

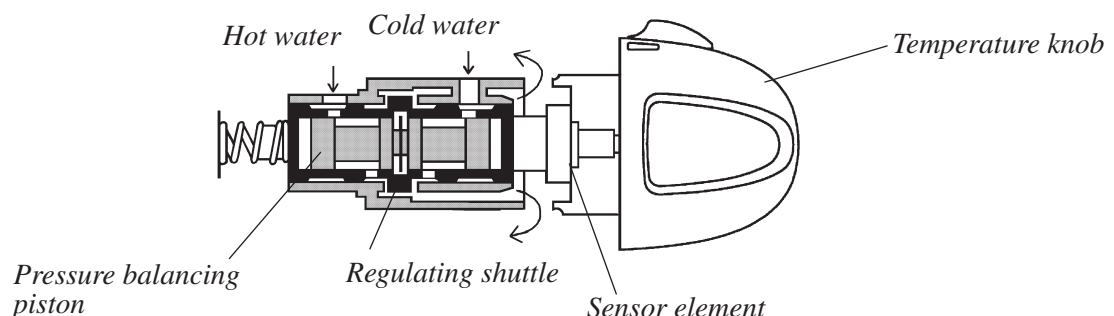

Tested and approved by FM Mattsson.

Every mixing valve is tested and approved.

The mixing valves are subjected to the following test:

- Tightness test with open and closed flow control.
- Tightness test of hot and cold water seat.
- Fail safe test.
- Cold water pressure 100 kPa > hot water pressure – Checking the mixed water temperature.
- Hot water pressure 100 kPa > cold water pressure – Checking the mixed water temperature.

Installation

Requirements

It is not necessary to attach filters, check-valves, pressure or thermostatic balancing devices as these functions are integrated in the mixer.

Stop valves can be installed on the supply connections before the mixer to simplify service or if it is demanded by domestic codes.

Hand-shower holder

A hand-shower holder is available for the mixer. It is attached to the outlet, between the mixer and the hose.

Rinse the supply pipework!

Flush the supply pipework before attaching the mixer eliminates the risk of filter clogging from unwanted impurities from the pipes.

Connection

Make sure that the connections are tight.

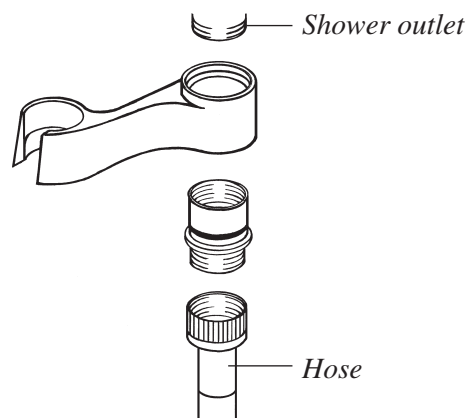

Hand-shower holder

Checking the delivered water temperature

With the temperature knob turned to the stop position, (without pressing the override button) the water temperature delivered should be just right for shower and bath. (appr. 36-38°C). The mixers are delivered, calibrated to provide this temperature with a hot water at 60-65°C and a cold water temperature at 10-15°C. If the provided water is too hot or too cold with the temperature knob in the stop position, with the override button unpressed, a recalibration is necessary. The procedure is as follows:

- Open the valve with the flow control and set the temperature, to the stop (unreleased override button position) desired level. It may be necessary to press the override button. Close the water flow: (It is not necessary to shut off the main supply.)
- Remove the centre cap with a screwdriver. Dismount the screw, and pull the knob straight out without moving the desired setting.

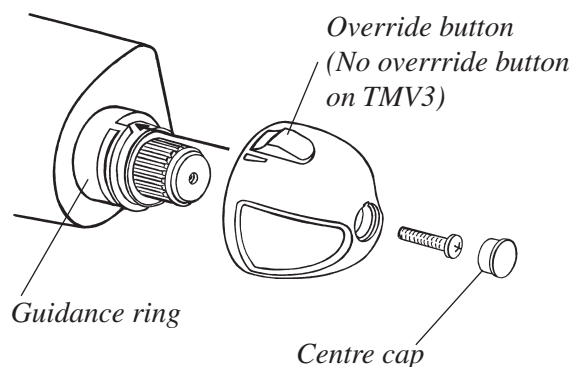

Calibration

- Replace the knob, now with the override button uppermost. Fit the lug inside the knob to the right of the guidance ring stop. See illustration.
- Reassemble and tighten the screw, attach the centre cap.
- Check the delivered water temperature. Note that the temperature, with the knob in its upper stop position, **must not exceed 46°C**.

For mixers installed in any UK National Health Service Installation (TMV 3), see enclosed NHS Requirements.

Please note that these mixing valves are not equipped with knob with override button, but are set to the desired maximum temperature.

If the tub outlet does not provide the correct temperature, the mixer needs to be recalibrated on the shower outlet, with a following check of the tub outlet.

Safety regulations

- | | |
|------------------------|---|
| Injurious risk! | Never remove the guidance ring, (inside the temperature knob) it is a protection against too hot water. |
| Injurious risk! | Never calibrate the mixer with a too low temperature on hot water inlet. If the hot water temperature later is increased, the mixed water temperature will follow, and a recalibration will be necessary. |
| Injurious risk! | If the temperature knob is turned past the stop, (after pressing the override button) the provided mixed water temperature is higher than what normally is required for a shower or bath. |
| Injurious risk! | Never unscrew a connection on the mixer without having shut off the main supply stop valve. |

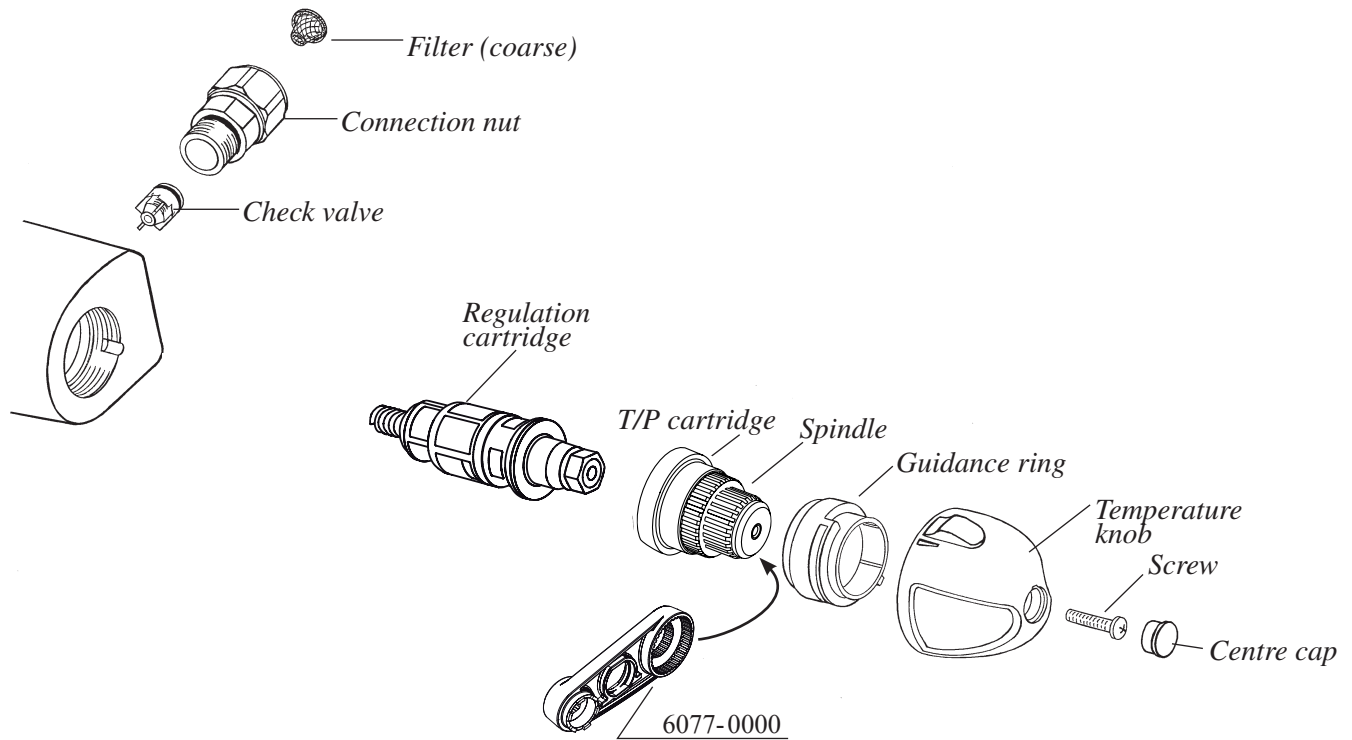

Function defect remedy

In order to guarantee the mixer's function, the connected water pressures and temperatures must meet the range within the given limits in Technical Data.

If installed in low pressure systems, make sure that the pressures are higher than 50 kPa.

If the mixing valve does not deliver sufficient amount of water or if the temperature regulation or temperature stability is disturbed, start by cleaning the filters.

If this action is not effective replace the regulation cartridge.

Cleaning the filters

150 c/c mixing valves

- Close the main supply valve and disconnect the mixer.
- The inlet filters are found in the connection nuts.
- Dismount the regulation cartridge, see "Regulation cartridge replacement".
- Pull off the filters from the cartridge. To remove the large filter the o-ring must first be dismantled.
- Clean all the filters (replace if necessary) and reassemble the parts.
- Refit the inlet filters into the connection nipples.
- Refit the mixing valve and open the main supply valve.
- Adjust the temperature override limit, see "Checking the delivered water temperature".

40 c/c mixing valves

Close the main supply valve before the inlet tubes are disconnected and removed to allow access to the inlet filters. They are found in the inlet adapters. The T/P cartridge filters are accessible just as described for 150 c/c models.

Regulation cartridge replacement

- Close the main supply valve.
- Remove the centre cap and screw on the temperature knob. Pull the knob straight out.
- Mark the positioning of the guidance ring (in relation to the body) and pull it off.
- Unscrew the T/P cartridge as follows: Press in the spindle [A] and hold it firmly in place to prevent it from rotating. Screw the nut [B] into place using FM Mattsson's service tool (Art.nr. 6077-0000) (see illustration).

- Dismount the regulation cartridge and install the new one in reverse order.
- Open the main supply valve and set the override temperature limit, see "Checking the delivered water temperature".

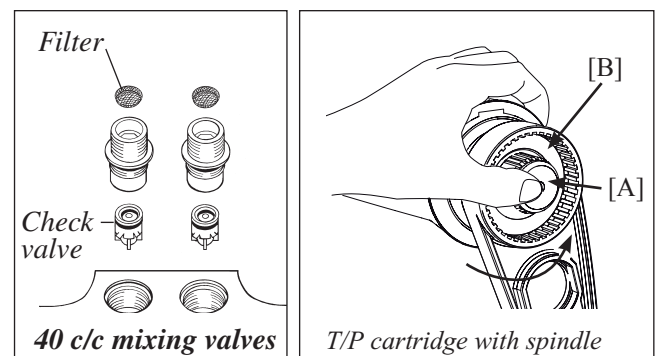

Dismounting and attaching the T/P cartridge head piece.

Check valve replacement

150 c/c mixing valves

- Close the main supply valve and disconnect the mixer.
- Unscrew the connection nipples. NOTE! The nipples are left hand threaded.
- Pull out the check valve from the connection nipple.
- Insert the new check valve into the connection nipple and refit the parts.
- Refit the mixing valve and open the main supply valve.

40 c/c mixing valves

The check valves are placed in the inlet connectors. It is not necessary to dismount the mixer, but **close the main supply valve** before the inlet tubes are disconnected. Unscrew the inlet connectors with a 10 mm hex socket wrench and replace the check valves. Insert the new check valves with the seat and the o-rings inwards to the connector. Reassemble all parts and open the main supply valve.

Shower - Spout diverter

If malfunction occurs in the spout-shower diverter, it most likely needs cleaning or replacement.

- Disconnect the hose from the mixer.

- Unscrew the diverter button.

Carefully secure the interior piston of the diverter cartridge from below with a screwdriver.

- Unscrew the cartridge downwards (12 mm hexagon key).

- Clean or replace the diverter cartridge, and reassemble in the reversed order.

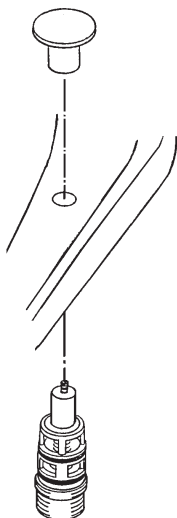

Packing (tap disc) replacement

The mixing valve is provided with only one packing. If the valve drips, replace the packing immediately.

- **Close the main supply valve.**

- Remove the centre cap and screw on the left hand knob. Pull the knob straight out.

- Dismount the flow control head.

- Replace the tap disc and refit the parts.

- Open the main supply valve.

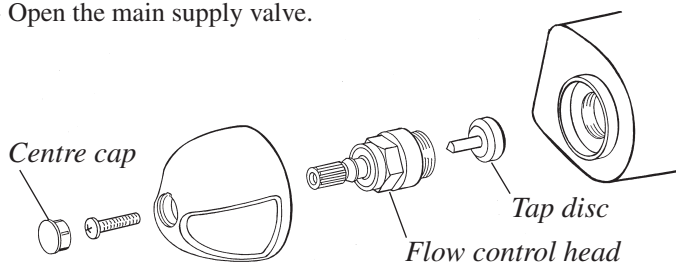

Technical data

Specifications:

Cold water supply temperature

5-25°C.

Hot water supply temperature

50-80°C.

Water supply pressure

50-1000 kPa.

Recommended operating pressure

100-500 kPa.

Max. test pressure

1600 kPa.

Min. flow rate

4 lit./min.

Temperature difference between

hot water and mixed water

Min. 10°C.

Materials:

The mixer body in dezincification resistant (DR) brass, chrome-plated or powder-coated. Knobs in plastic, standard version chrome-plated.

Connections:

150-153 c/c mixers: Inlet internal G3/4.

Outlet external G1/2.

40 c/c mixers and concealed mixers:

Inlet and outlet external G1/2.

Regular inspection and maintenance

Check the mixer function at regular intervals, minimum once every year. Make sure that the correct temperature is obtained from the mixer. If it is equipped with a temperature knob, the regulation function is tested by turning the knob towards cold and towards hot. By sensing the mixed water it is determined that the water is becoming colder/hotter relative to the turning direction of the knob. Also make sure that sufficient flow is supplied from the mixer. If the mixer is not operating satisfactory see "Function defect remedy".

Cleaning

The mixing valve finish is best preserved by regular cleaning using a soft rag and soap solution, washing with pure water and polishing with a dry rag. Do not ever use lime dissolvents, acidic or grinding detergents. Use household vinegar to remove lime spots and wash with water. The powder coated surfaces may not be exposed to acetone or caustic solution.

Cleaning the aerator

Unscrew the aerator every now and then and clean the insert from impurities. If the insert is affected by lime deposits, wash with vinegar solution.

No aluminium chloride, hydrochloric acid or phosphoric acid on chrome

The chrome plated surface on the mixers is not resistant to aluminium chloride. Dark spots will arise. Aluminium chloride is used against perspiration. When cleaning the tiles with hydrochloric acid, the mixers must be protected. Hydrochloric acid dissolves chromium. Phosphoric acid can be present in very concentrated detergents and damages the chromium surface layer.

Pressure drop

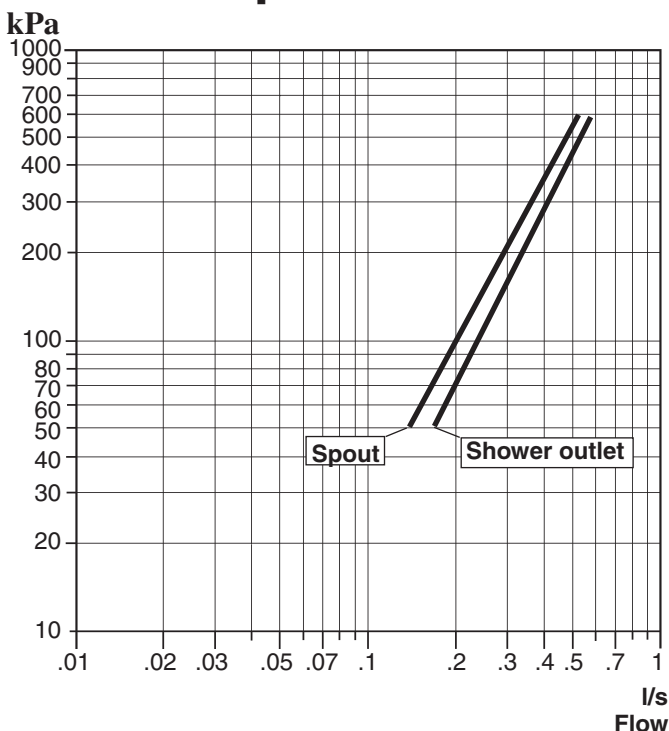

FM Mattsson

FM Mattsson, Box 480, SE-792 27 MORA, SWEDEN

www.fmmattsson.com